

NPN Silicon Double Transistor

- To be used as a current mirror
- Good thermal coupling and V_{BE} matching
- High current gain
- Low collector-emitter saturation voltage
- Pb-free (RoHS compliant) package¹⁾
- Qualified according AEC Q101

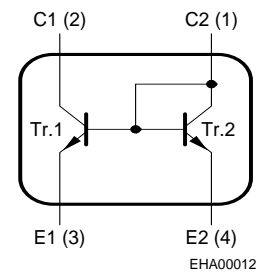
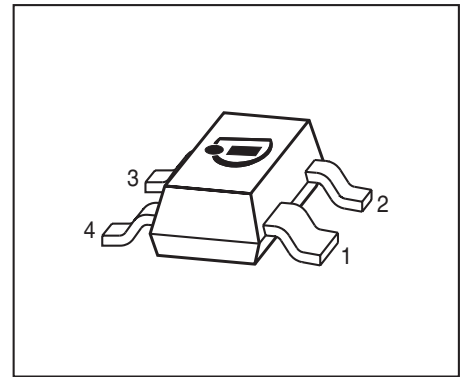

Type	Marking	Pin Configuration				Package
BCV61	1Js	1 = C2	2 = C1	3 = E1	4 = E2	SOT143
BCV61B	1Ks	1 = C2	2 = C1	3 = E1	4 = E2	SOT143
BCV61C	1Ls	1 = C2	2 = C1	3 = E1	4 = E2	SOT143

Maximum Ratings

Parameter	Symbol	Value	Unit
Collector-emitter voltage (transistor T1)	V_{CEO}	30	V
Collector-base voltage (open emitter) (transistor T1)	V_{CBO}	30	
Emitter-base voltage	V_{EBS}	6	
DC collector current	I_C	100	mA
Peak collector current	I_{CM}	200	
Base peak current (transistor T1)	I_{BM}	200	
Total power dissipation, $T_S = 99\text{ °C}$	P_{tot}	300	mW
Junction temperature	T_j	150	°C
Storage temperature	T_{stg}	-65 ... 150	

¹⁾Pb-containing package may be available upon special request

Thermal Resistance
Electrical Characteristics at $T_A = 25^\circ\text{C}$, unless otherwise specified

Parameter	Symbol	≤ 170			K/W Unit
		Values			
		min.	typ.	max.	

DC Characteristics of T1

Collector-emitter breakdown voltage $I_C = 10\text{ mA}, I_B = 0$	$V_{(BR)CEO}$	30	-	-	V
Collector-base breakdown voltage $I_C = 10\text{ }\mu\text{A}, I_E = 0$	$V_{(BR)CBO}$	30	-	-	
Emitter-base breakdown voltage $I_E = 10\text{ }\mu\text{A}, I_C = 0$	$V_{(BR)EBO}$	6	-	-	
Collector cutoff current $V_{CB} = 30\text{ V}, I_E = 0$	I_{CBO}	-	-	15	nA
Collector cutoff current $V_{CB} = 30\text{ V}, I_E = 0, T_A = 150^\circ\text{C}$	I_{CBO}	-	-	5	μA
DC current gain ²⁾ $I_C = 0.1\text{ mA}, V_{CE} = 5\text{ V}$	h_{FE}	100	-	-	-
DC current gain ²⁾ $I_C = 2\text{ mA}, V_{CE} = 5\text{ V}$	h_{FE}				
	BCV61A	110	180	220	
	BCV61B	200	290	450	
	BCV61C	420	520	800	
Collector-emitter saturation voltage ²⁾ $I_C = 10\text{ mA}, I_B = 0.5\text{ mA}$ $I_C = 100\text{ mA}, I_B = 5\text{ mA}$	V_{CEsat}	-	90	250	mV
		-	200	600	
Base-emitter saturation voltage ²⁾ $I_C = 10\text{ mA}, I_B = 0.5\text{ mA}$ $I_C = 100\text{ mA}, I_B = 5\text{ mA}$	V_{BEsat}	-	700	-	
		-	900	-	
Base-emitter voltage ²⁾ $I_C = 2\text{ mA}, V_{CE} = 5\text{ V}$ $I_C = 10\text{ mA}, V_{CE} = 5\text{ V}$	$V_{BE(ON)}$	580	660	700	
		-	-	770	

¹For calculation of R_{thJA} please refer to Application Note Thermal Resistance

²Puls test: $t \leq 300\text{ }\mu\text{s}, D = 2\%$

Electrical Characteristics at $T_A = 25^\circ\text{C}$, unless otherwise specified.

Parameter	Symbol	Values			Unit
		min.	typ.	max.	
Characteristics					
Base-emitter forward voltage $I_E = 10 \mu\text{A}$ $I_E = 250 \text{ mA}$	V_{BES}	0.4 -	- -	- 1.8	V
Matching of transistor T1 and transistor T2 at $I_{E2} = 0.5\text{mA}$ and $V_{\text{CE1}} = 5\text{V}$ $T_A = 25^\circ\text{C}$ $T_A = 150^\circ\text{C}$	I_{C1} / I_{C2}	- 0.7 0.7	- - -	- 1.3 1.3	-
Thermal coupling of transistor T1 and transistor T2 1) T1: $V_{\text{CE}} = 5\text{V}$ Maximum current of thermal stability of I_{C1}	I_{E2}	-	5	-	mA
AC characteristics for transistor T1					
Transition frequency $I_C = 10 \text{ mA}$, $V_{\text{CE}} = 5 \text{ V}$, $f = 100 \text{ MHz}$	f_T	-	250	-	MHz
Collector-base capacitance $V_{\text{CB}} = 10 \text{ V}$, $f = 1 \text{ MHz}$	C_{cb}	-	0.95	-	pF
Emitter-base capacitance $V_{\text{EB}} = 0.5 \text{ V}$, $f = 1 \text{ MHz}$	C_{eb}	-	9	-	
Noise figure $I_C = 200 \mu\text{A}$, $V_{\text{CE}} = 5 \text{ V}$, $R_S = 2 \text{ k}\Omega$, $f = 1 \text{ kHz}$, $\Delta f = 200 \text{ Hz}$	F	-	2	-	dB
Short-circuit input impedance $I_C = 1 \text{ mA}$, $V_{\text{CE}} = 10 \text{ V}$, $f = 1 \text{ kHz}$	h_{11e}	-	4.5	-	k Ω
Open-circuit reverse voltage transf.ratio $I_C = 1 \text{ mA}$, $V_{\text{CE}} = 10 \text{ V}$, $f = 1 \text{ kHz}$	h_{12e}	-	2	-	10^{-4}
Short-circuit forward current transf.ratio $I_C = 1 \text{ mA}$, $V_{\text{CE}} = 10 \text{ V}$, $f = 1 \text{ kHz}$	h_{21e}	100	-	900	-
Open-circuit output admittance $I_C = 1 \text{ mA}$, $V_{\text{CE}} = 10 \text{ V}$, $f = 1 \text{ kHz}$	h_{22e}	-	30	-	μS

1) Witout emitter resistor. Device mounted on alumina 15mm x 16.5mm x 0.7mm

Test circuit for current matching

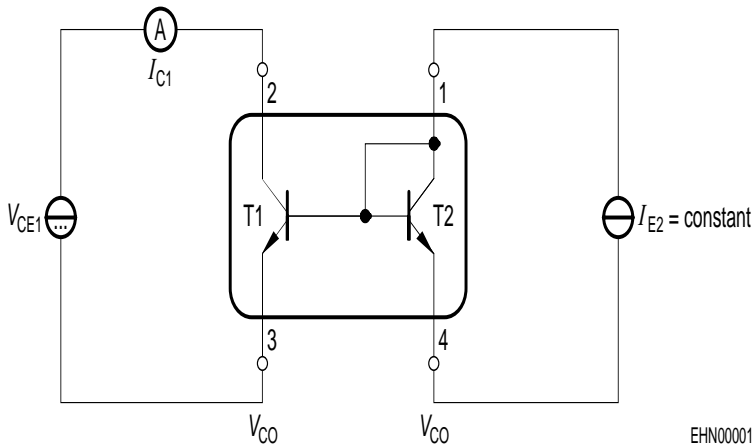

Note: Voltage drop at contacts: $V_{CO} < 2/3 V_T = 16\text{mV}$

Characteristic for determination of V_{CE1} at specified R_E range with I_{E2} as parameter under condition of $I_{C1}/I_{E2} = 1.3$

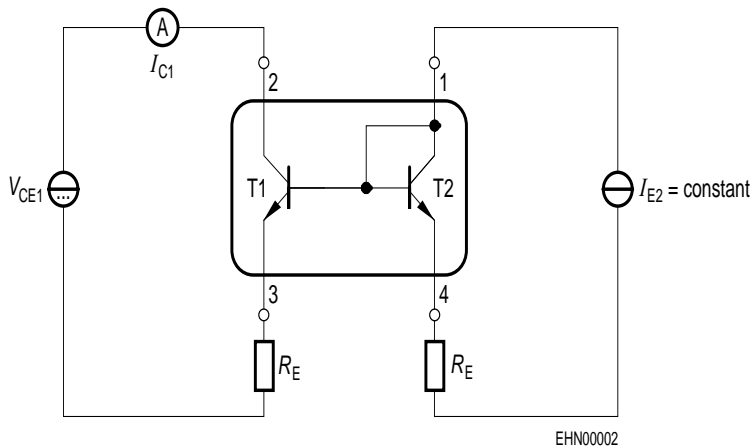

Note: BCV61 with emitter resistors

Collector-base capacitance $C_{cb} = f(V_{CB})$

Emitter-base capacitance $C_{eb} = f(V_{EB})$

Total power dissipation $P_{tot} = f(T_S)$

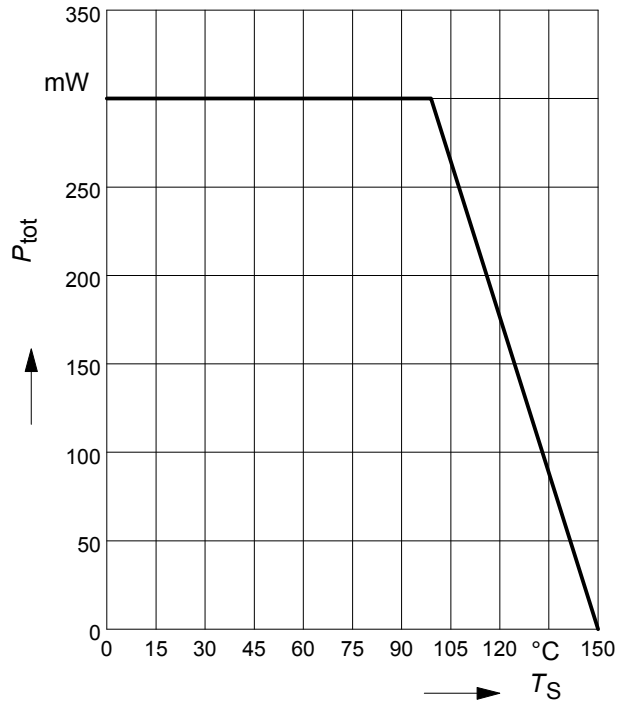
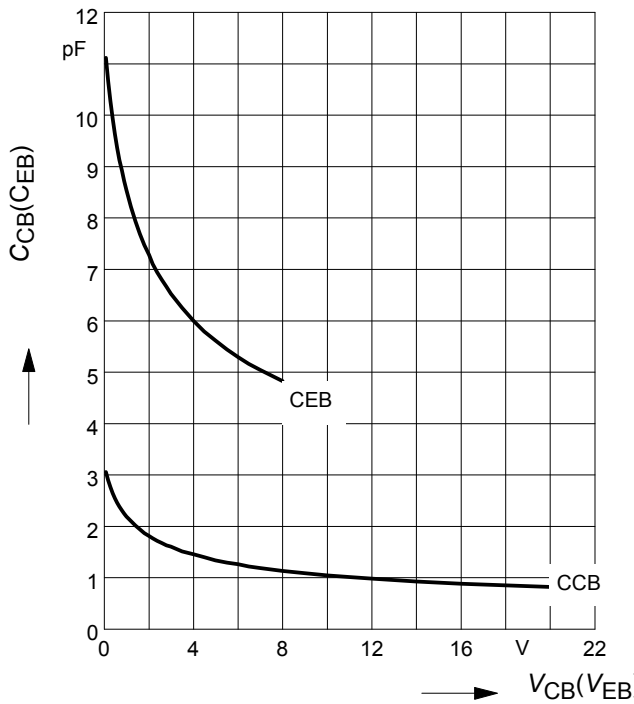

Permissible pulse load

$P_{totmax} / P_{totDC} = f(t_p)$

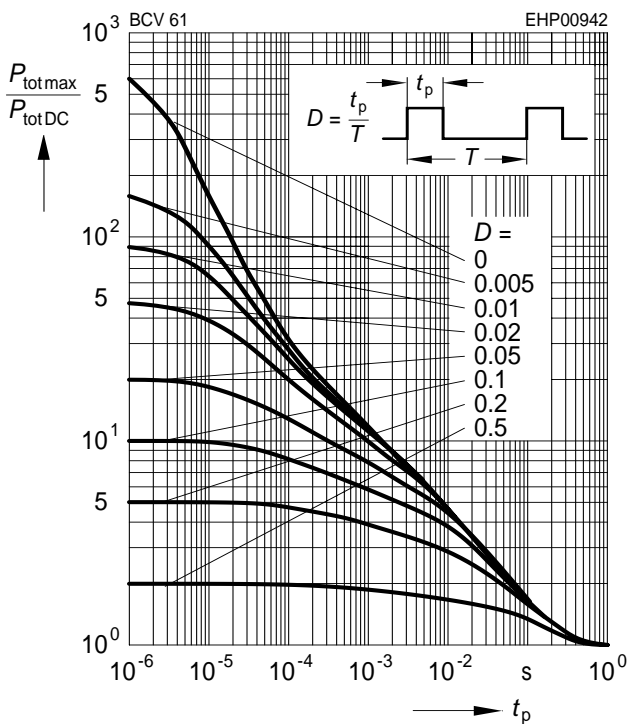

Package Outline

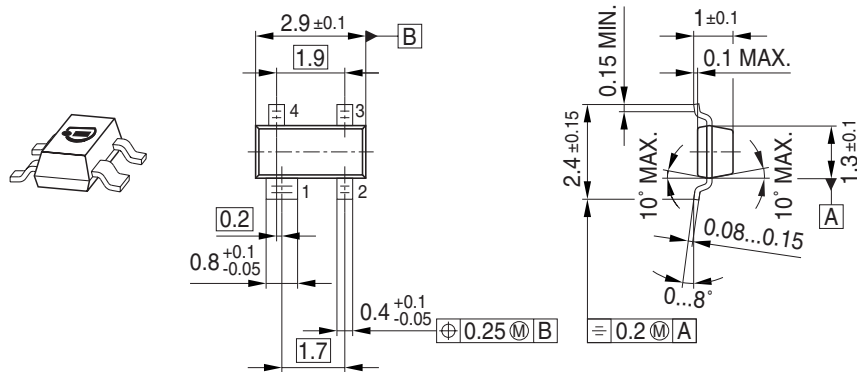

Foot Print

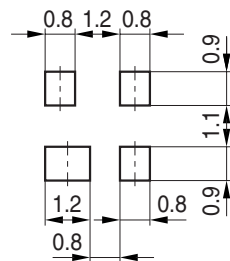

Marking Layout (Example)

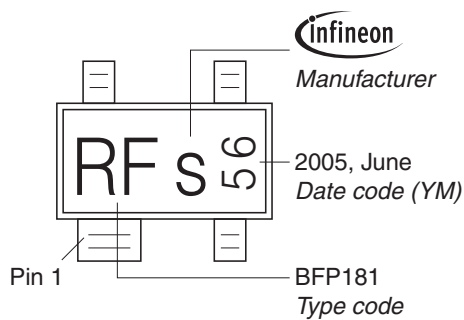

Standard Packing

Reel ϕ 180 mm = 3.000 Pieces/Reel
 Reel ϕ 330 mm = 10.000 Pieces/Reel

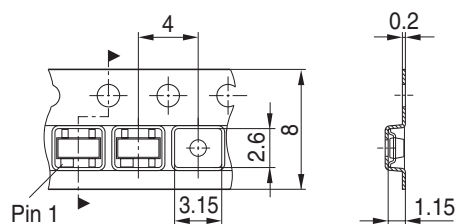

Published by
Infineon Technologies AG
81726 München, Germany
© Infineon Technologies AG 2007.
All Rights Reserved.

Attention please!

The information given in this data sheet shall in no event be regarded as a guarantee of conditions or characteristics ("Beschaffheitsgarantie"). With respect to any examples or hints given herein, any typical values stated herein and/or any information regarding the application of the device, Infineon Technologies hereby disclaims any and all warranties and liabilities of any kind, including without limitation warranties of non-infringement of intellectual property rights of any third party.

Information

For further information on technology, delivery terms and conditions and prices please contact your nearest Infineon Technologies Office (www.infineon.com).

Warnings

Due to technical requirements components may contain dangerous substances. For information on the types in question please contact your nearest Infineon Technologies Office.

Infineon Technologies Components may only be used in life-support devices or systems with the express written approval of Infineon Technologies, if a failure of such components can reasonably be expected to cause the failure of that life-support device or system, or to affect the safety or effectiveness of that device or system.

Life support devices or systems are intended to be implanted in the human body, or to support and/or maintain and sustain and/or protect human life. If they fail, it is reasonable to assume that the health of the user or other persons may be endangered.